

Part Number: PT725-35120

Kit Contents

Item #	Quantity Req'd.	Description
1	1	Flasher Assembly (F/A)
2	1	Wire Harness
3	1	Sub Wire Harness
4	2	Plastic Tie (300mm)
5	4	Plastic Tie (200mm)
6	13	Plastic Tie (150mm)
7	1	Packing
8	2	Bolt (M5)
9	1	Towing Tail Relay
10	2	Fuse (30A)
11	1	Sub Wire Harness (F/A)
12	1	Owner's Manual

* Depending on the vehicle, the plastic tie of Item #6 may have excess quantity.

Hardware Bag Contents

Item #	Quantity Req'd.	Description

Additional Items Required For Installation

Item #	Quantity Req'd.	Description

Conflicts

--

Recommended Tools

Personal & Vehicle Protection	Notes
Safety Goggles	
Seat Covers	
Floor Protectors	
Special Tools	Notes
L.E.D. Tester	S.S.T. 00002-62195
Installation Tools	Notes
Torque Wrench	
Ratchet 3/8" Drive	
6" Extension	
10mm Socket	
8mm Socket	
Nylon Removal Tool	
Awl (hook type)	
Side Cutters	
Jewelers Screwdriver	
Special Chemicals	Notes

General Applicability

Vehicles with DRL

Recommended Sequence of Application







Item #	Accessory
1	Trailer Hitch
2	Trailer Wire Harness

Vehicle Service Parts

(May be required for reassembly)

Item #	Quantity Req'd.	Description
1	1	Foot rest (58190-04021)

Legend

	STOP: Damage to the vehicle may occur. Do not proceed until process has been complied with.
	OPERATOR SAFETY: Use caution to avoid risk of injury.
	CAUTION: A process that must be carefully observed in order to reduce the risk of damage to the accessory/vehicle and to ensure a quality installation.
	TOOLS & EQUIPMENT: Used in Figures calls out the specific tools and equipment recommended for this process.
	REVISION MARK: This mark highlights a change in installation with respect to previous issue.
	SAFETY TORQUE: This mark indicates that torque is related to safety.

This draft is the product of DENSO Products and Services Americas, Inc., which will not be liable for any modifications made without DENSO's prior written consent.

Care must be taken when installing this accessory to ensure damage does not occur to the vehicle. The installation of this accessory should follow approved guidelines to ensure quality installation.

These guidelines can be found in the "Accessory Installation Practices" document.

This document covers such items as:

- Vehicle Protection (use of covers and blankets, cleaning chemicals, etc.).
- Safety (eye protection, rechecking torque procedure, etc.).
- Vehicle Disassembly/Reassembly (panel removal, part storage, etc.).
- Electrical Component Disassembly/Reassembly (battery disconnection, connector removal, etc.).

Please see your Toyota dealer for a copy of this document.

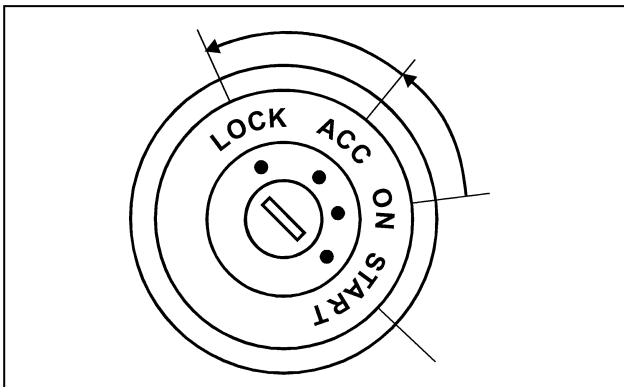

1. Supplemental Restraint System (SRS)

- (a) Failure to carry out procedures listed below could result in possible deployment of airbag, personal injury, or unnecessary repairs to SRS.
- (b) Turn the key switch to the LOCK position.
- (c) Remove the key from the ignition switch.

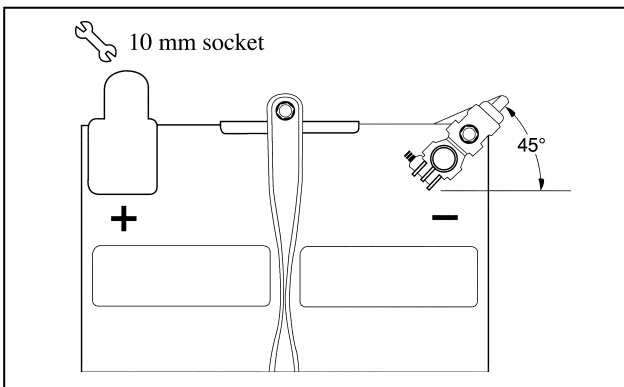

- (d) Disconnect the negative battery cable.



- (e) Never use a voltmeter to trouble shoot any of the harnesses or connectors to the SRS. Accidentally probing the connectors to the SRS can lead to deployment of the airbag.
- (f) SRS wire harness loom/cover is bright yellow in color.

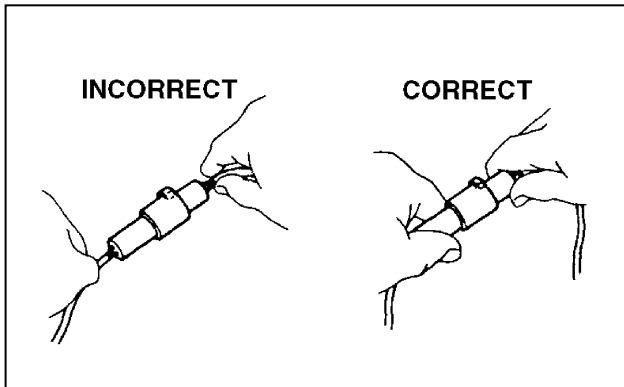

2. Wiring Precautions

- (a) DO NOT pull on vehicle wires and/or wire harness. To uncouple electrical connectors, pull only on the connector itself.
- (b) Use nylon ties and adhesive foam strips to secure the vehicle harness and the trailer wire harness.
- (c) Ensure all wires are properly insulated from ground.
- (d) When installing the trailer wire harness make sure it is not cut or perforated by any sharp metal objects.

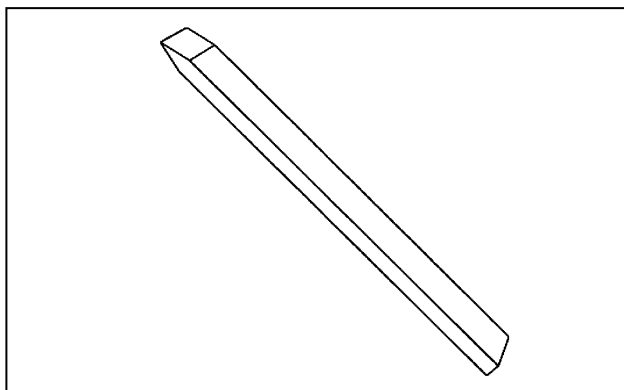

3. General Practices and Procedures

- (a) Before starting installation, refer to the supplemental restraint system procedures in Section 1.
- (b) Take care not to scratch any part of the vehicle. Bind the tips of tools (clip remover, slot screw driver, etc.) with vinyl tape to prevent damage to any part of the car, or use a nylon removal tool (resin based prying tool).
- (c) Use a small parts container to store removed bolts and tapping screws so that they can be reassembled correctly.
- (d) Ensure seat/floor protectors are in position.
- (e) After fastening plastic ties, clip away all the excess of the ties using diagonal pliers.

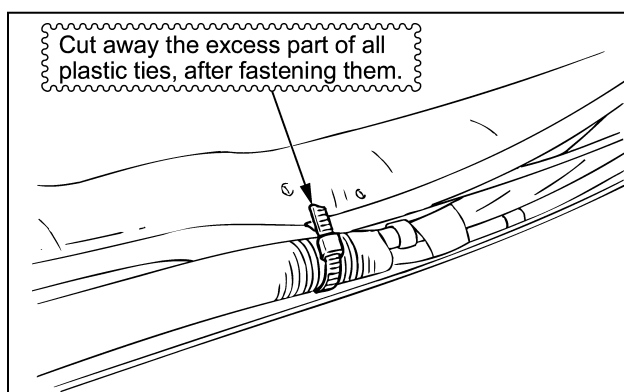

Installation Outline for Trailer Wire Harness Components

■ D-Cab (Long)

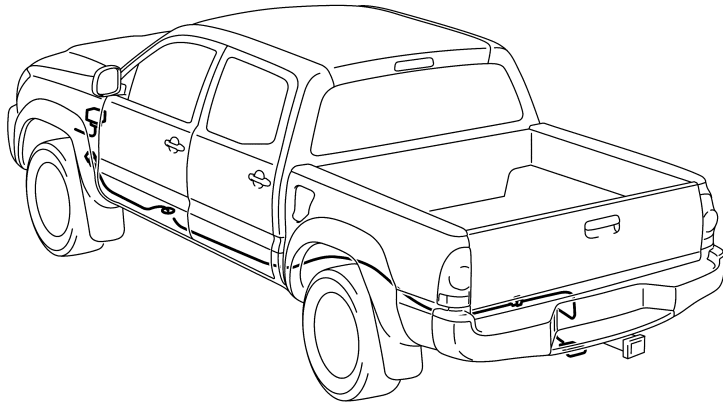

■ C-Cab

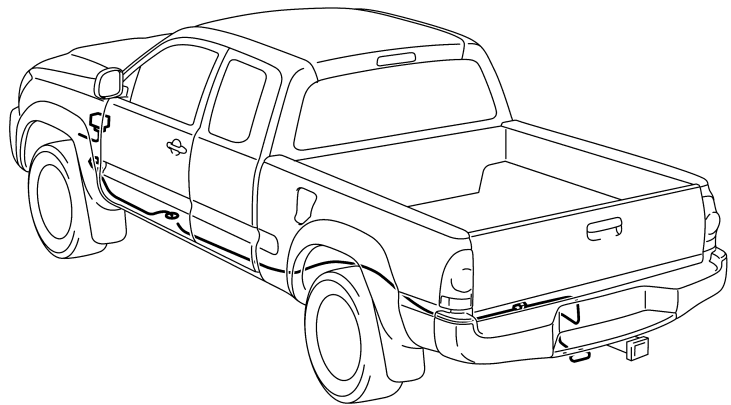

■ B-Cab

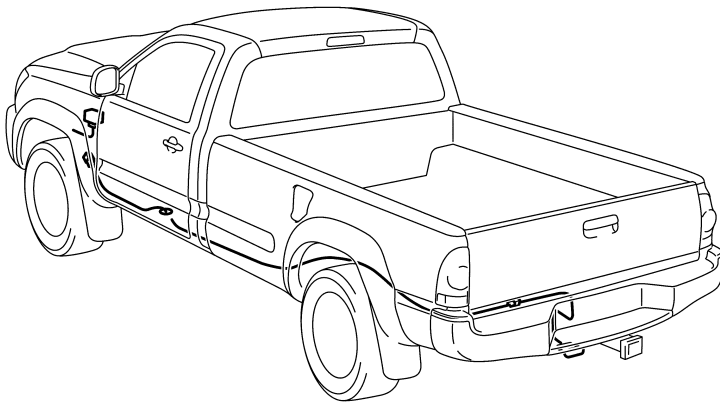

Trailer Wire Harness Parts Description

(1) FLASHER ASSEMBLY

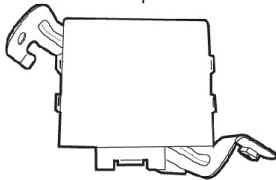

(2) WIRE HARNESS

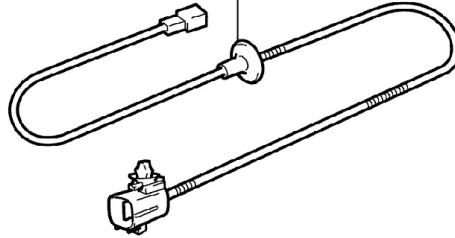

(3) SUB WIRE HARNESS

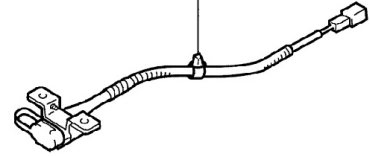

(4) PLASTIC TIE (300MM)



(5) PLASTIC TIE (200MM)



(6) PLASTIC TIE (150MM)



(7) PACKING

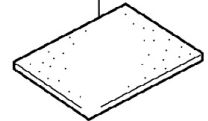

(8) BOLT (M5)



(9) TOWING TAIL RELAY

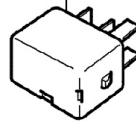

(10) FUSE (30A)



(11) FLASHER ASSEMBLY
SUB WIRE HARNESS

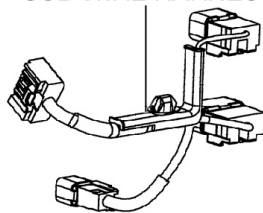

(12) OWNER'S MANUAL

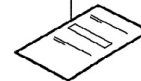

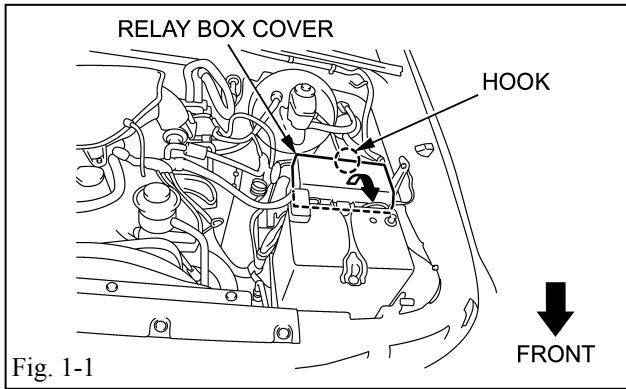

1. Parts Removal

(a) Before installation, disconnect the negative (-) battery cable from the terminal.

+ (b) Relay box cover.

(1) Remove relay box cover. (Fig. 1-1)

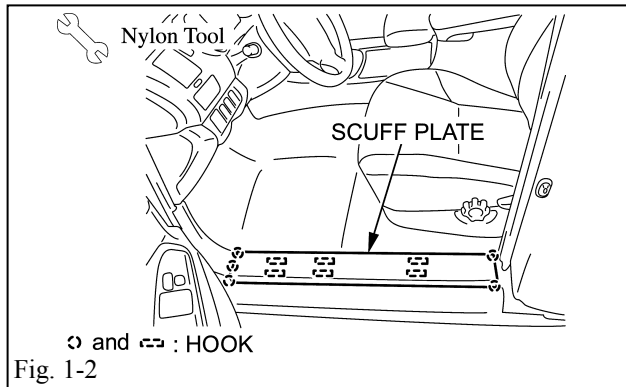

(c) Scuff plate

(1) Remove scuff plate. (Fig. 1-2)

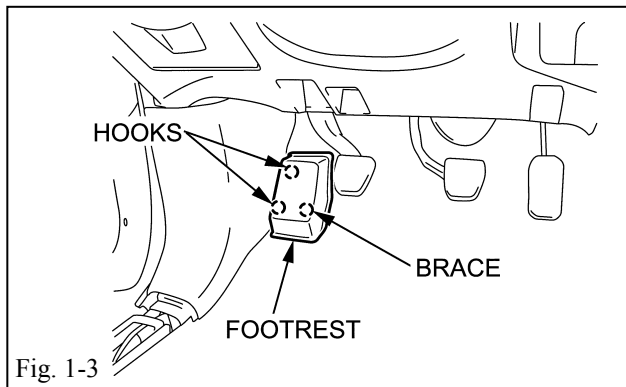

(d) Footrest

(1) Remove footrest. (Fig. 1-3)



NOTE: Discard the foot rest. A replacement foot rest (PN: 58190-04021) must be used.

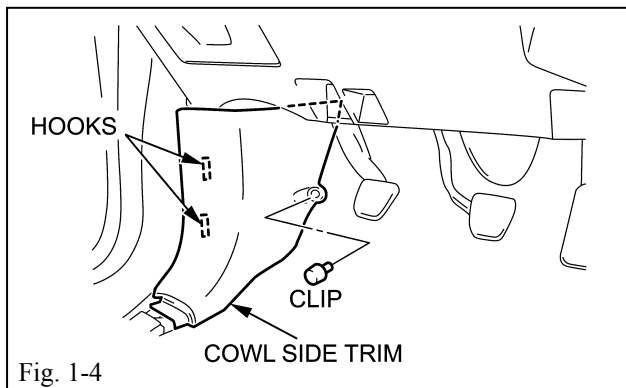

(e) Cowl side trim

- (1) Remove the clip from cowl side trim by turning it counter clockwise. Remove the cowl side trim. (Fig. 1-4)

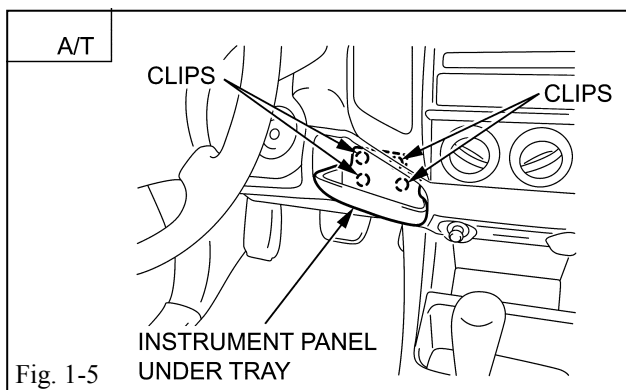

*Perform the work in step (f) only for the A/T vehicle.

(f) Instrument panel under tray

-  (1) Use the steering tilt and telescope function to lift up the steering wheel and pull it toward you so that the instrument panel under tray does not interfere with the steering wheel before removing the instrument panel hole cover. (Fig. 1-5)
- (2) Remove instrument panel hole cover. (Fig. 1-5)

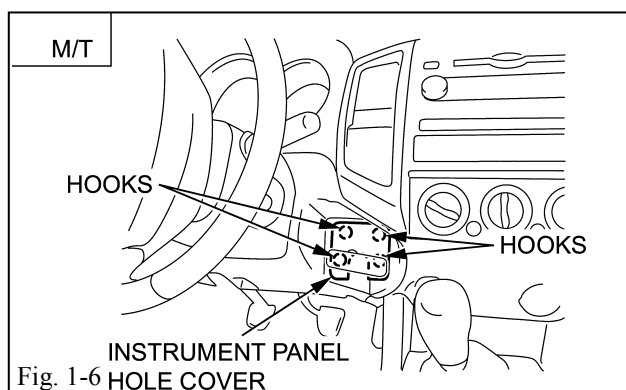

*Perform the work in step (g) only for the M/T vehicle.

(g) Instrument panel hole cover

-  (1) Use the steering tilt and telescope function to lift up the steering wheel and pull it toward you so that the instrument panel under tray does not interfere with the steering wheel before removing the instrument panel under tray. (Fig. 1-6)
- (2) Remove instrument panel hole cover. (Fig. 1-6)

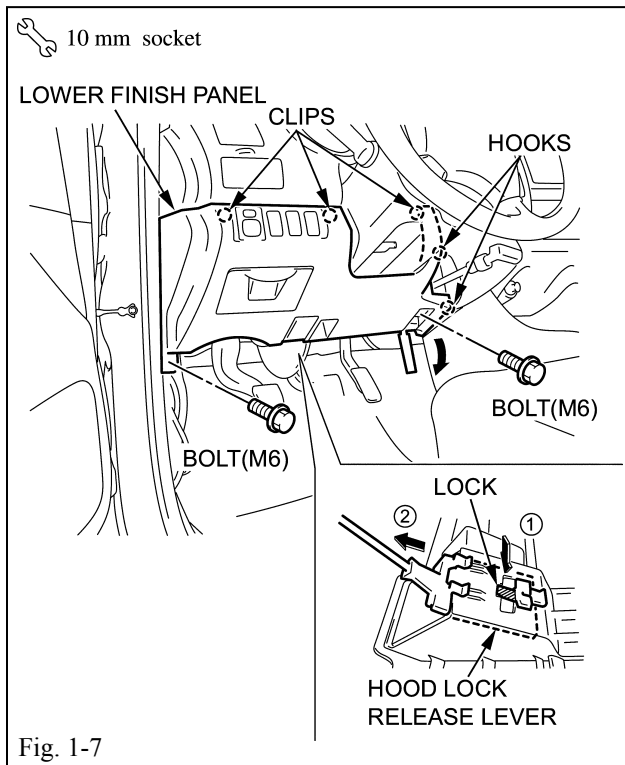

Fig. 1-7

(h) Lower finish panel

- (1) Remove two bolts from lower finish panel and remove lower finish panel. (Fig. 1-7)
- (2) Pull out to remove the hood lock release lever while pressing the hood lock release lever lock. (Fig. 1-7)

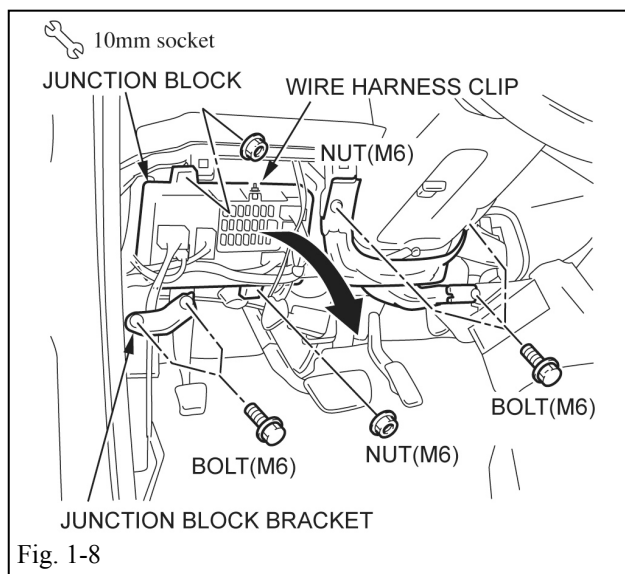
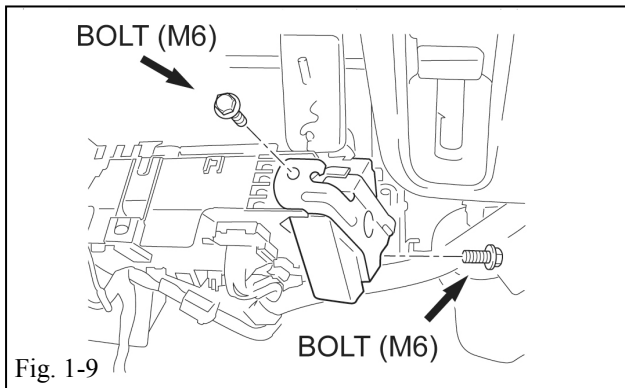

Fig. 1-8

(i) Junction block

- (1) Remove three bolts from steering column bracket and remove bracket. (Fig. 1-8)
- (2) Remove wire harness clip from top of junction box. (Fig. 1-8)
- (3) Remove two bolts from junction bracket and remove junction bracket. (Fig. 1-8)
- (4) Remove two nuts from junction block and pull the junction block toward you. (Fig. 1-8)



(j) Flasher assembly

- (1) Remove two bolts from flasher assembly mounting bracket and save bolt for reuse. (Fig. 1-9)

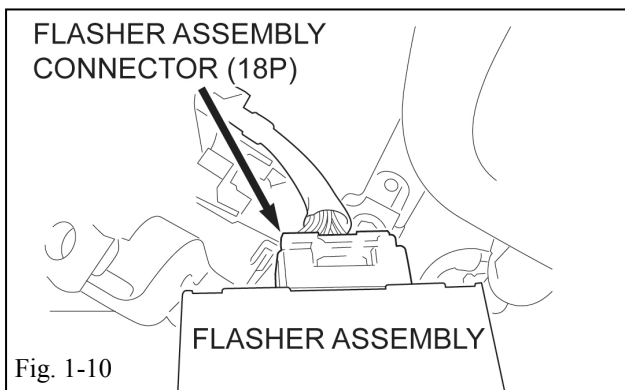

- (2) Disconnect the flasher assembly wire harness 18-pin connector. (Fig. 1-10)

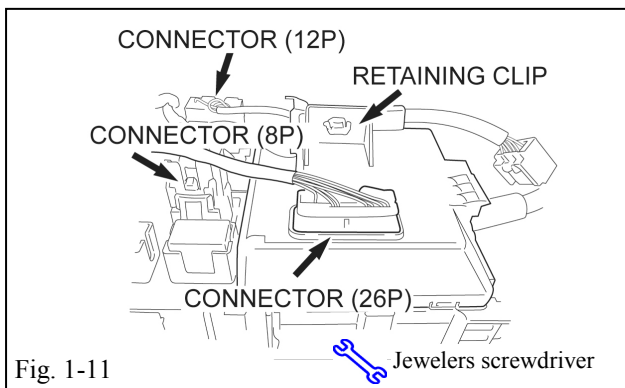

- (3) Temporarily disconnect 26-pin connector from the junction block. (Fig. 1-11)

- (4) Disconnect flasher assembly sub wire harness 8-pin connector on the back of the junction block. (Fig. 1-11)

NOTE: Use jewelers screwdriver when removing the 8-pin connector.

- (5) Disconnect flasher assembly sub wire harness retaining clip and 12-pin connector on the back of the junction. Discard the sub wire harness. (Fig. 1-11)

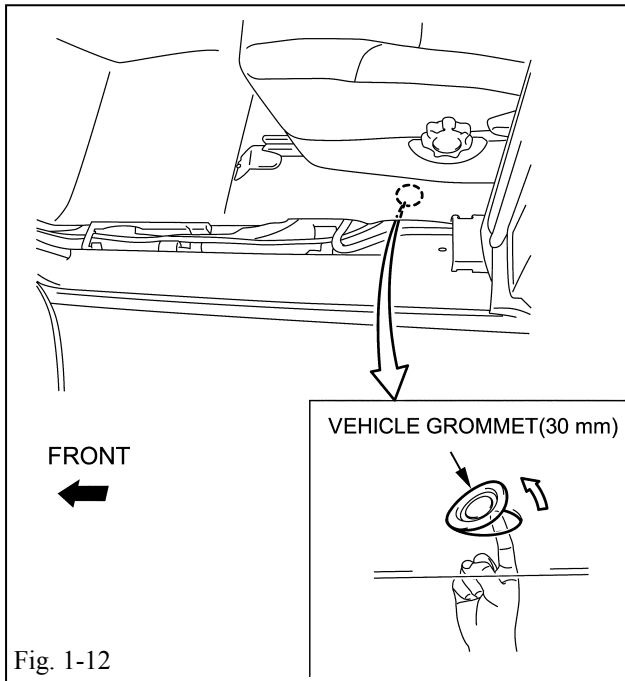
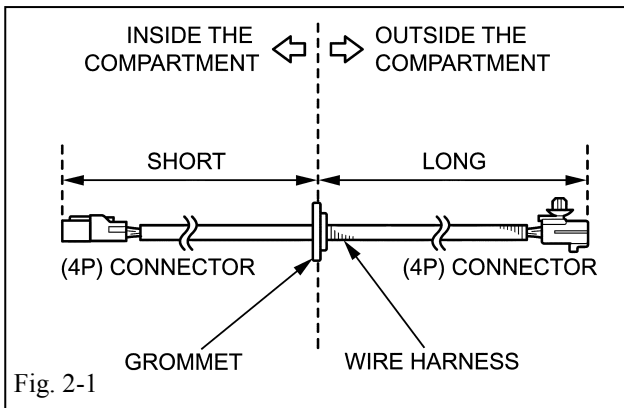

Fig. 1-12

(k) Vehicle grommet (30mm)

- (1) Remove the vehicle grommet (30mm) by pushing it up with your fingers from the vehicle bottom inside the compartment. (Discard) (Fig. 1-12)



2. Installation

(a) Wire harness

- (1) Determine the correct interior and exterior sections of the wire harness by referring to the wire harness. (Fig. 2-1)

(b) Fit the grommet

-  (1) Considering the routing of the wire harness in the following process, position the interior wire harness over the vehicle harness inboard side of the vehicle chassis (LH) side member. (Fig. 2-2)

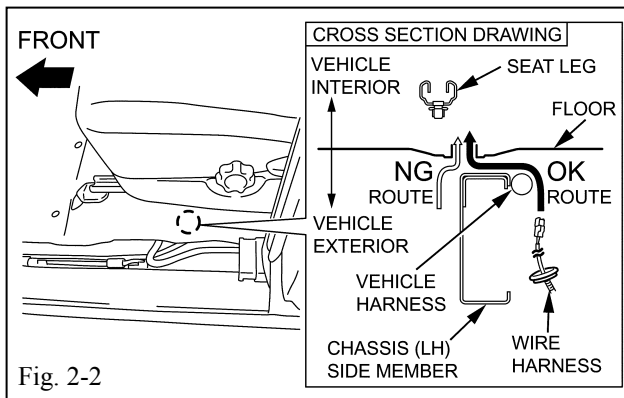

- (2) Starting from the underside of the vehicle route the interior 4-pin wire harness through the vehicle hole. (Fig. 2-2)
- (3) Fit the wire harness grommet into the vehicle hole from which the vehicle grommet was removed. (Fig. 2-2)

(c) Securing wire harness (inside the vehicle)

- (1) Lift the three vehicle clamps and route the wire harness along the vehicle wire harness. (Fig. 2-3)

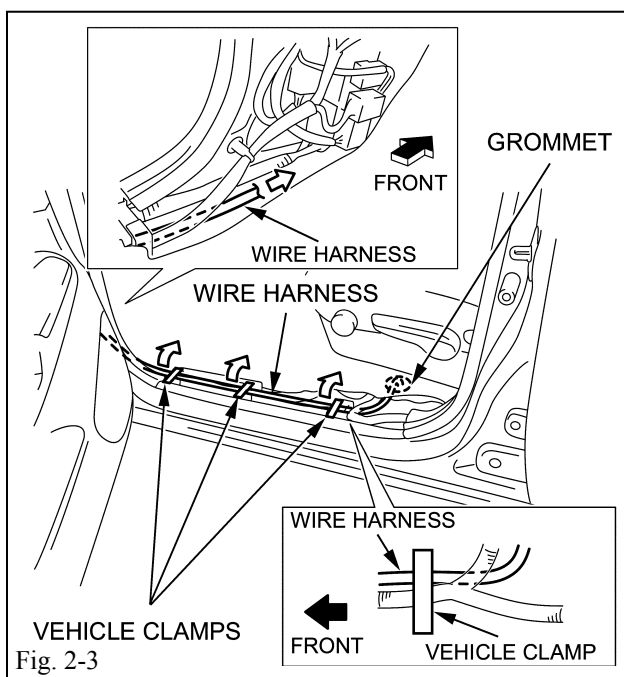

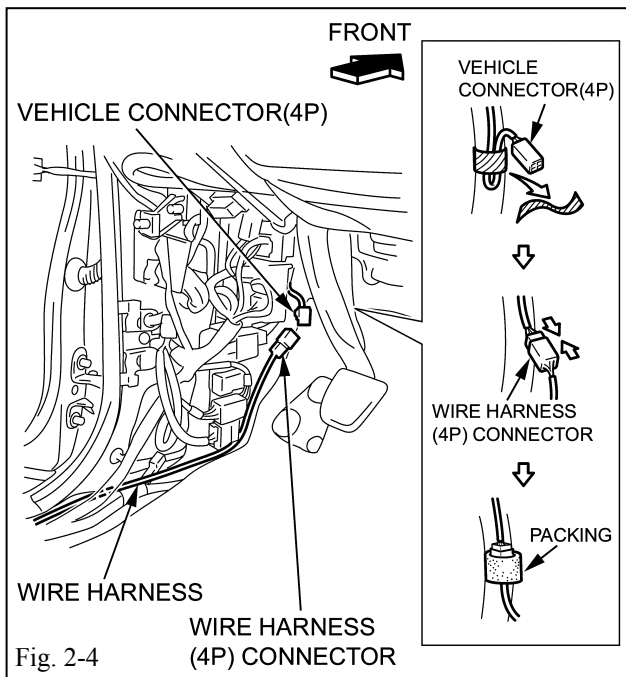

(d) Connecting the 4-pin wire harness connector to the 4-pin vehicle connector.

- (1) Remove the tape for fixing the 4-pin vehicle connector. (Fig. 2-4)
- (2) Wrap the packing around the 4-pin wire harness connector of the towing wire harness.

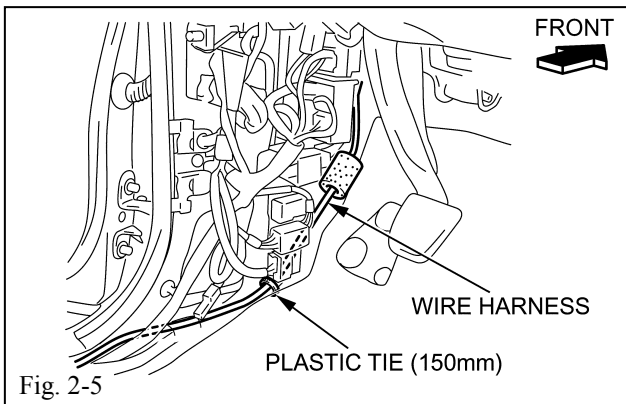

(e) Securing wire harness (inside the vehicle)

- (1) Secure the wire harness to the vehicle harness with a plastic tie (150mm). (Fig. 2-5)

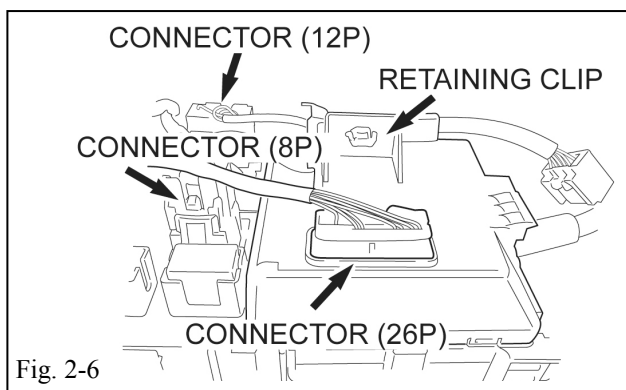

(f) Flasher assembly installation

- (1) Connect the new flasher assembly sub wire harness 8-pin and 12-pin connectors to the plugs on the junction block and clip the retaining clip in place. (Fig. 2-6)
- (2) Re-install the previously removed 26-pin connector. (Fig. 2-6)

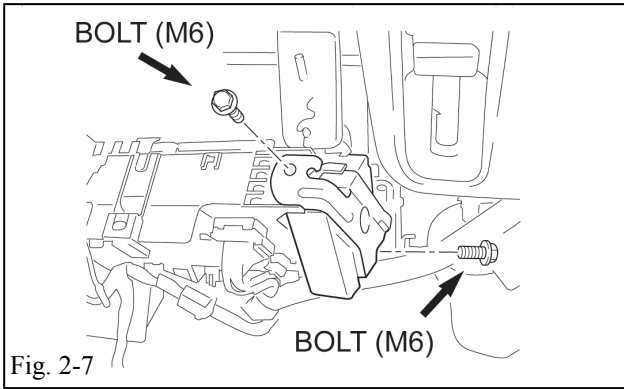

- (3) Attach the flasher assembly to the junction block using the two bolts (M6) [from step (j)(1) page 9] and tighten the two bolts. (Fig. 2-7)

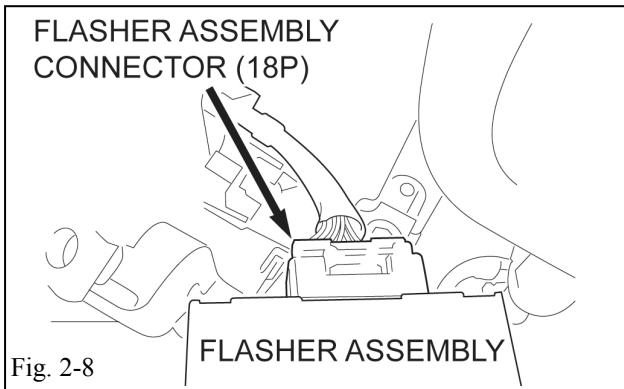

- (4) Connect the 18-pin connector of the flasher assembly sub wire harness to the flasher assembly. (Fig. 2-8)

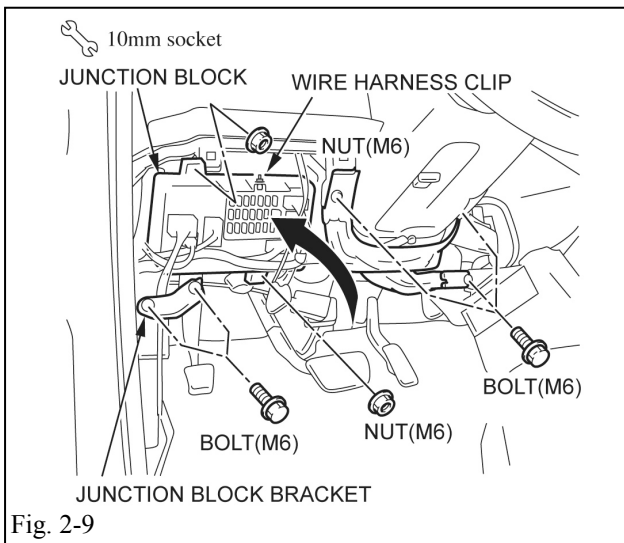

- (5) Install the junction block to original location. (Fig. 2-9)

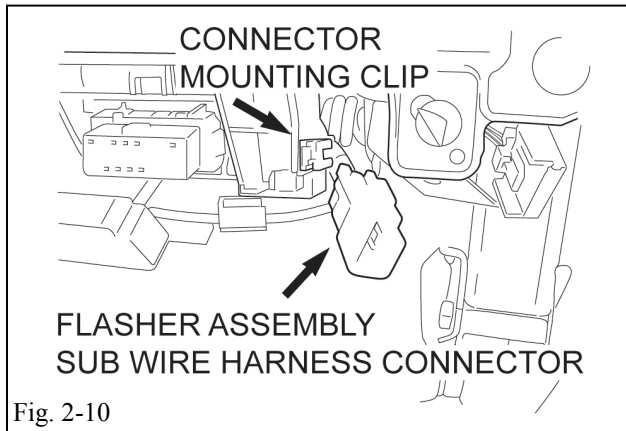

- (6) Route the flasher assembly sub wire harness 4-pin connector to the bottom area of the junction block and attach it to the connector mounting clip. (Fig. 2-10)

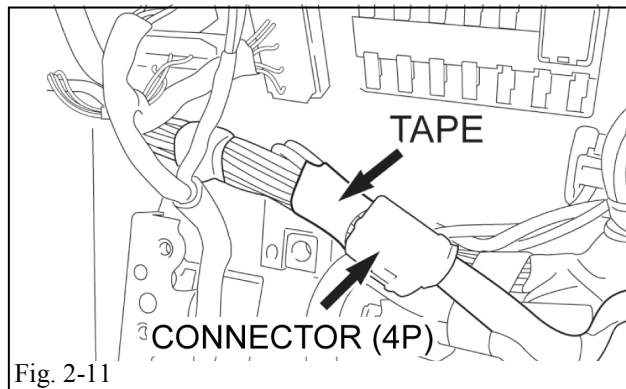

- (7) Remove tape for retaining the 4-pin connector to vehicle wire harness. (Fig. 2-11)

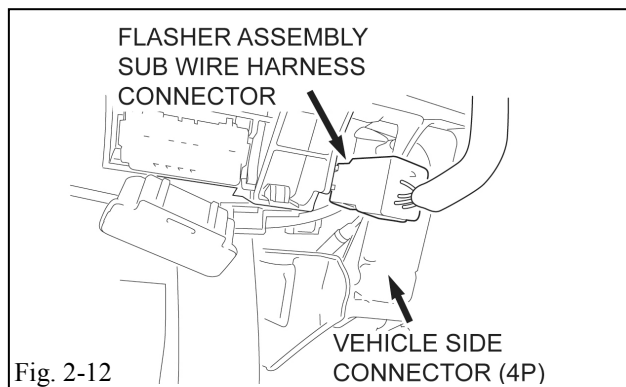

- (8) Connect vehicle side 4-pin connector to flasher assembly sub wire harness 4-pin connector. (Fig. 2-12)

For B-cab Installation Refer to Installation Procedure, Page #15.

For C-cab Installation Refer to Installation Procedure, Page #18.

For D-cab (Long) Installation Refer to Installation Procedure, Page #21.

For D-cab (Super Long) Installation Refer to Installation Procedure, Page #23.

For [B-cab, C-cab, D-cab (Long), D-cab (Super Long)] – Securing Sub Wire Harness, Refer to Installation Procedure, Page #26.

HINT: The trailer wire harness generally follows the same path as the vehicle wire harness that is routed to the rear of the vehicle.

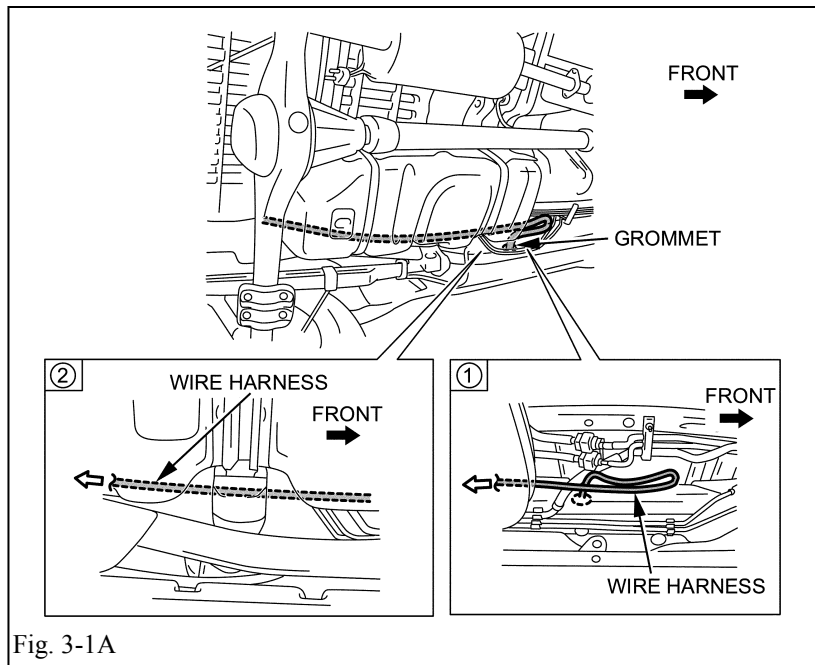

Fig. 3-1A

3. B-cab truck under bed section

(a) Routing of wire harness (underside of vehicle)

- (1) Route the 4-pin wire harness as shown. (Fig. 3-1A) (Fig. 3-1B)

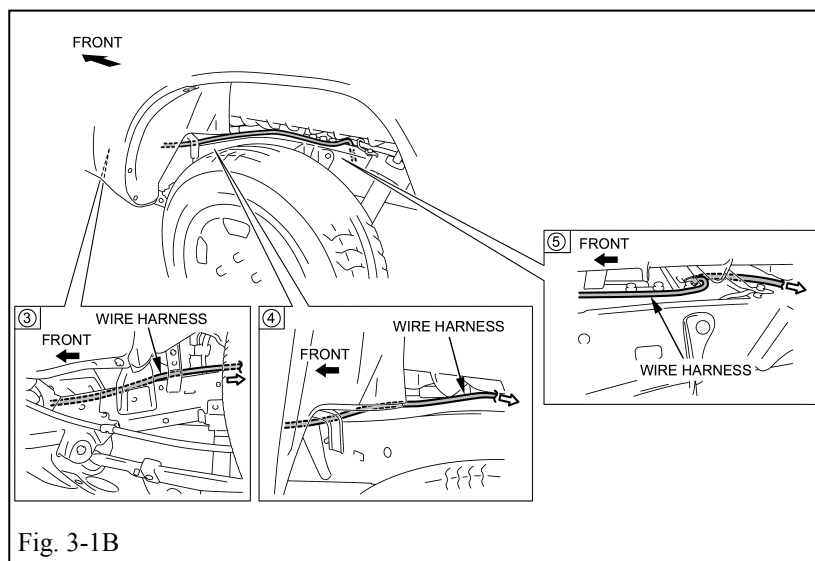
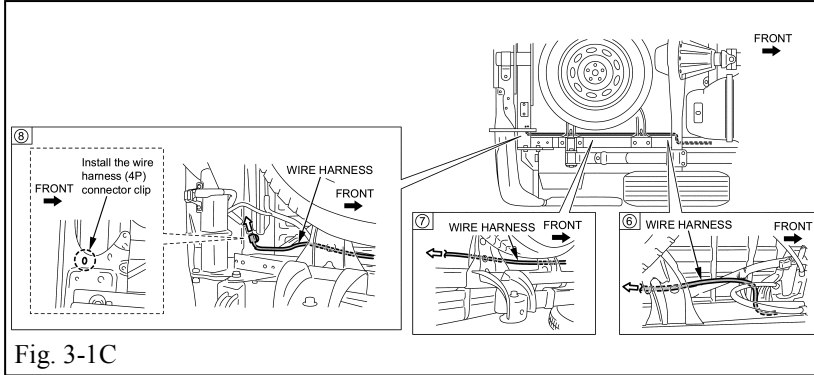
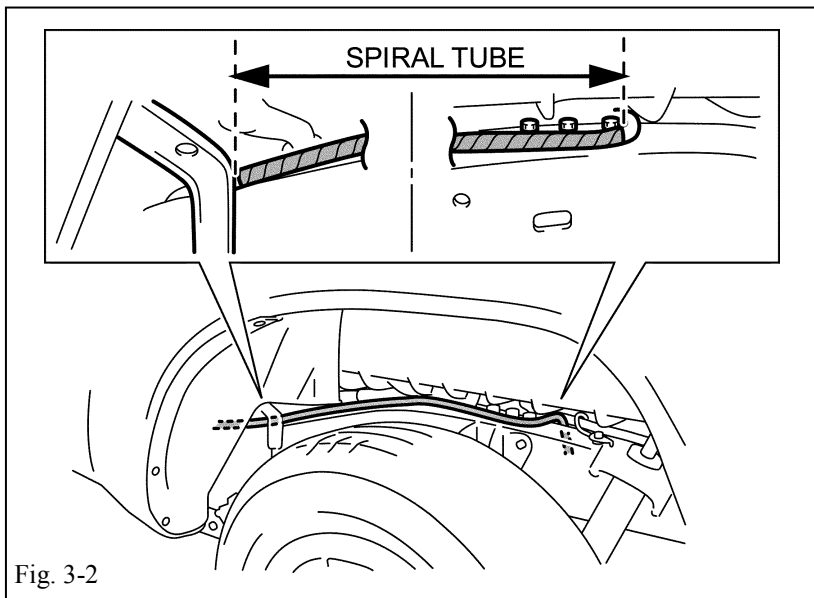

Fig. 3-1B



- (2) Install the wire harness 4-pin connector clip to the position illustrated. (Fig. 3-1C)



- (b) Positioning of wire harness
 - (1) Route the wire harness spiral tube to the position in the figure of the vehicle driver side. (Fig. 3-2)

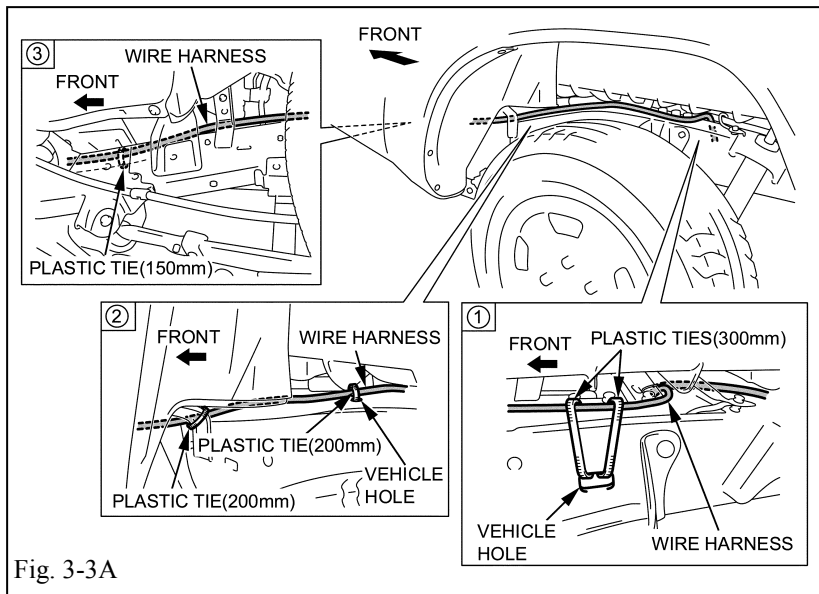

Fig. 3-3A

(c) Securing the wire harness
(underside of vehicle)

- (1) Install the wire harness plastic ties as shown in the figure. Use the correct amount of ties as listed in the tables below.
(Fig. 3-3A) (Fig. 3-3B)

PLASTIC TIES	
SIZE	QTY
150	1
200	2
300	2

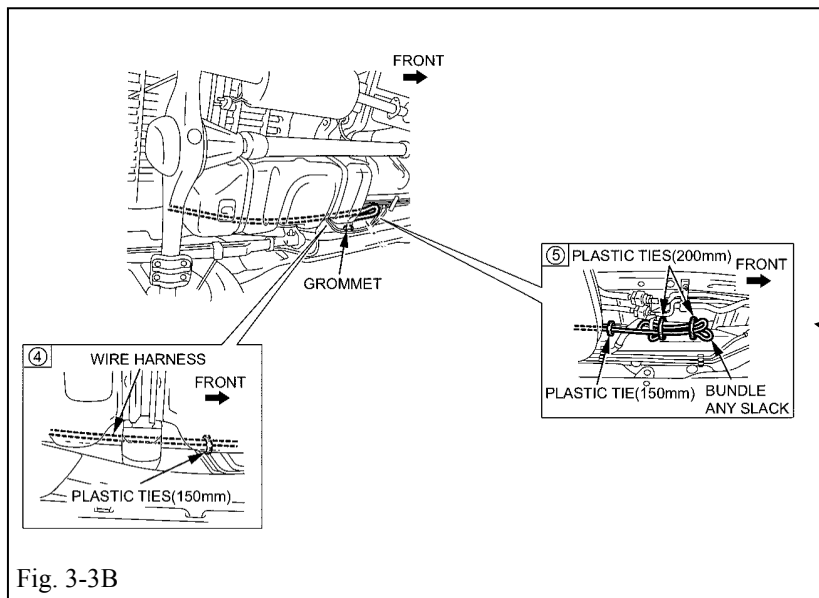



Fig. 3-3B

PLASTIC TIES	
SIZE	QTY
150	2
200	2
300	0

 Position the plastic tie securing the wire to avoid touching the brake line tube.

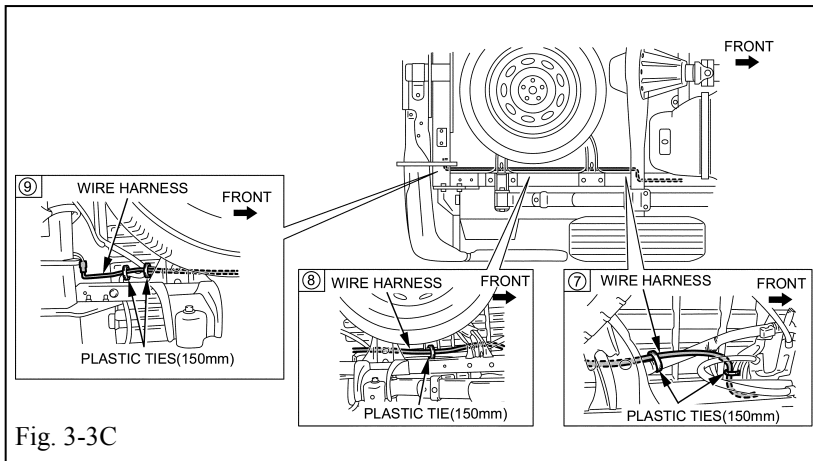

Fig. 3-3C

- ⚠** (2) Route the wire harness so that it does not interfere with the brake line, fuel line, and others. Use the correct amount of ties as listed in the table below. (Fig. 3-3C)

PLASTIC TIES	
SIZE	QTY
150	5
200	0
300	0

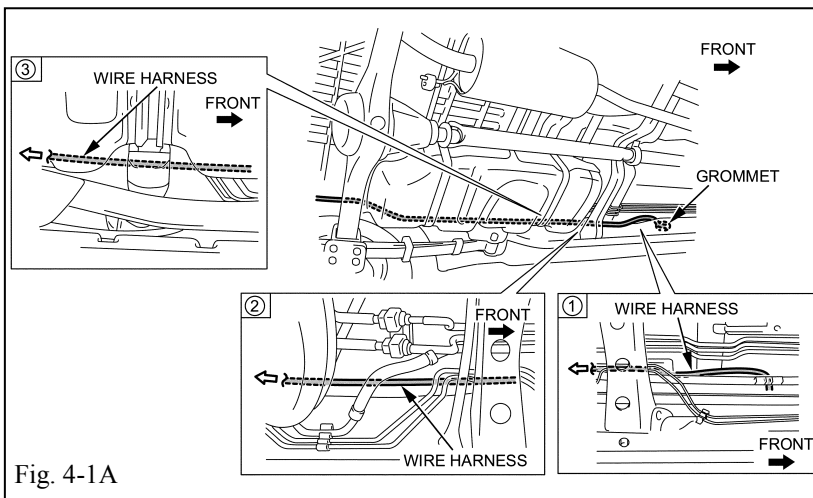

Fig. 4-1A

4. C-cab truck under bed section

- (a) Routing of wire harness (underside of vehicle)
- (1) Route the 4-pin wire harness as shown in the figure. (Fig. 4-1A) (Fig. 4-1B)

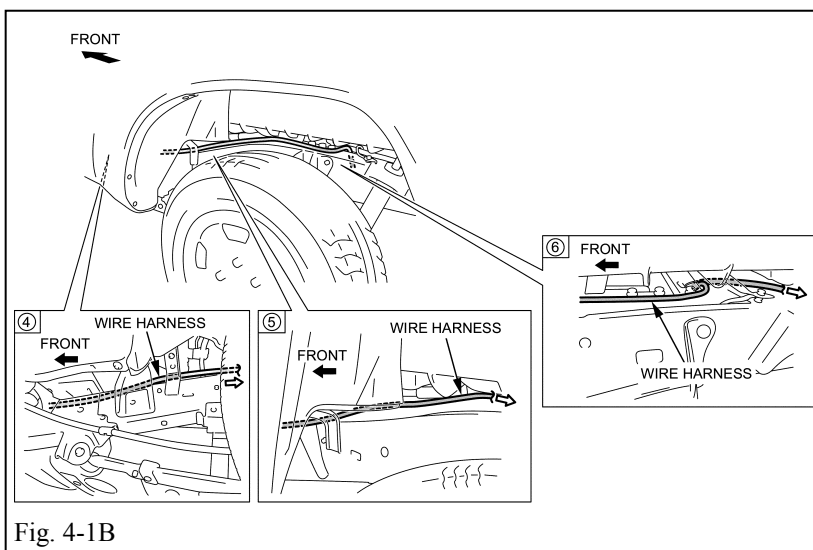

Fig. 4-1B

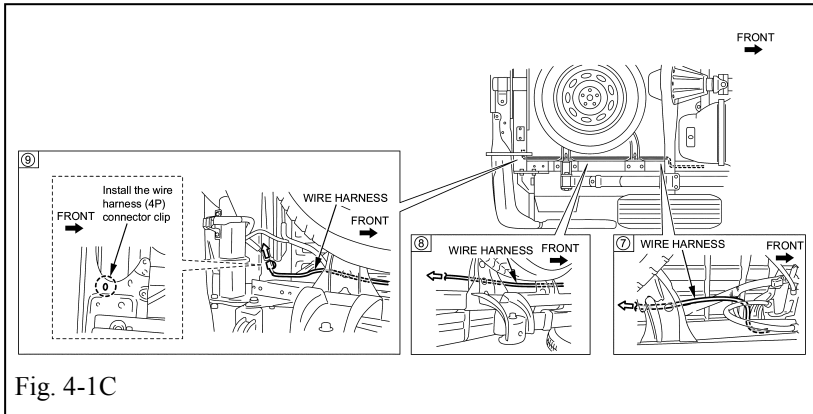

Fig. 4-1C

- (2) Install the wire harness 4-pin connector clip to the position shown in the figure. (Fig. 4-1C)

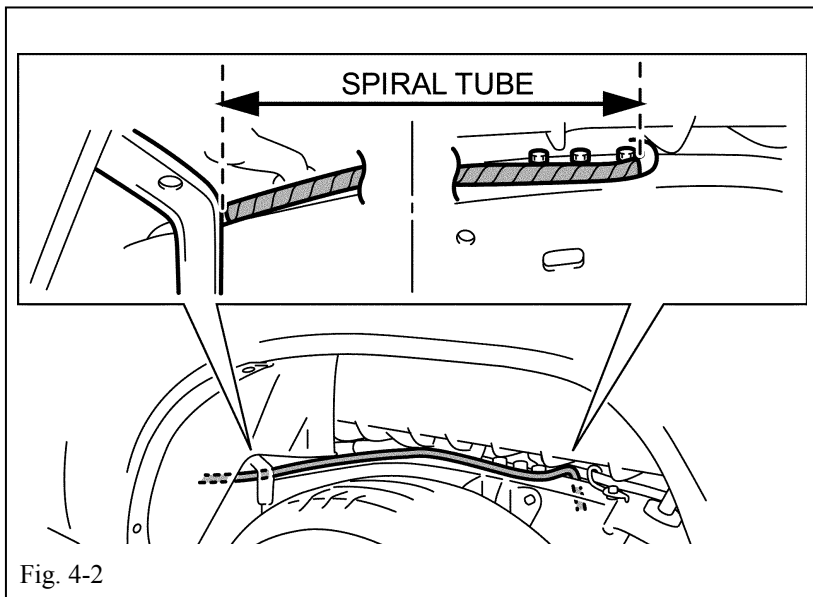

Fig. 4-2

- (b) Positioning of wire harness

- (1) Route the wire harness spiral tube to the position shown in the figure. (Fig. 4-2)

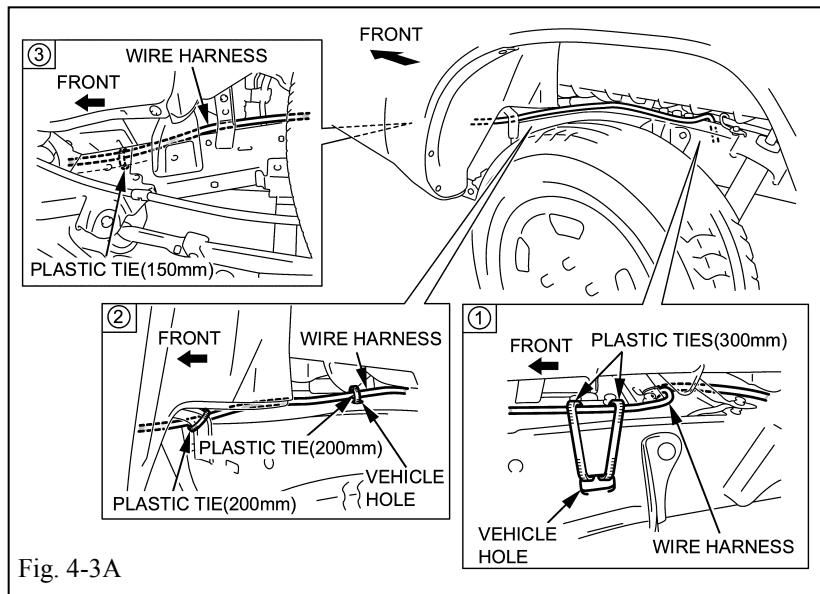

Fig. 4-3A

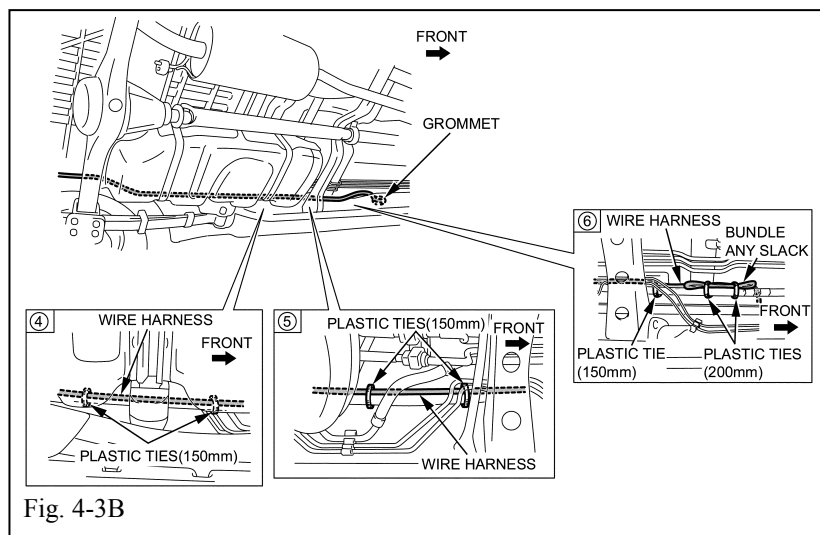

Fig. 4-3B

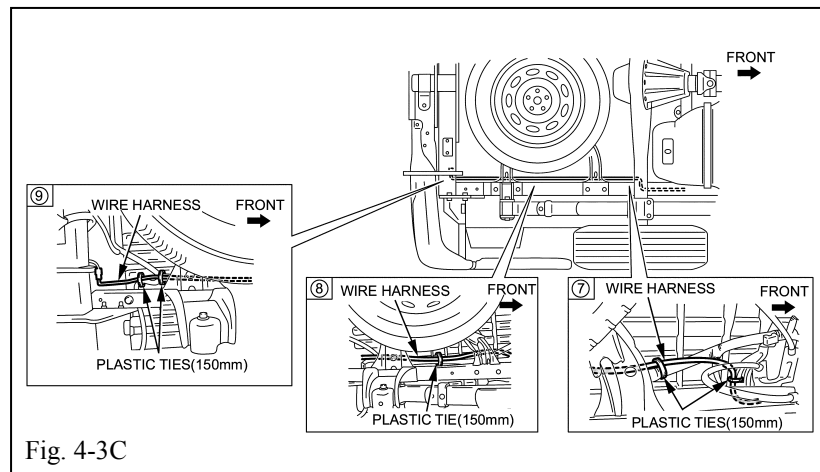



Fig. 4-3C

(c) Positioning of wire harness (underside of vehicle)

- (1) Secure the wire harness so that it does not interfere with the brake line, fuel line, and others. Use the correct amount of ties as listed in the tables below. (Fig. 4-3A) (Fig. 4-3B)

PLASTIC TIES	
SIZE	QTY
150	1
200	2
300	2

PLASTIC TIES	
SIZE	QTY
150	5
200	2
300	0

-  (2) Secure the wire harness so that it does not interfere with the brake line, fuel line, and others. Use the correct amount of ties as listed in the tables below.

PLASTIC TIES	
SIZE	QTY
150	5
200	0
300	0

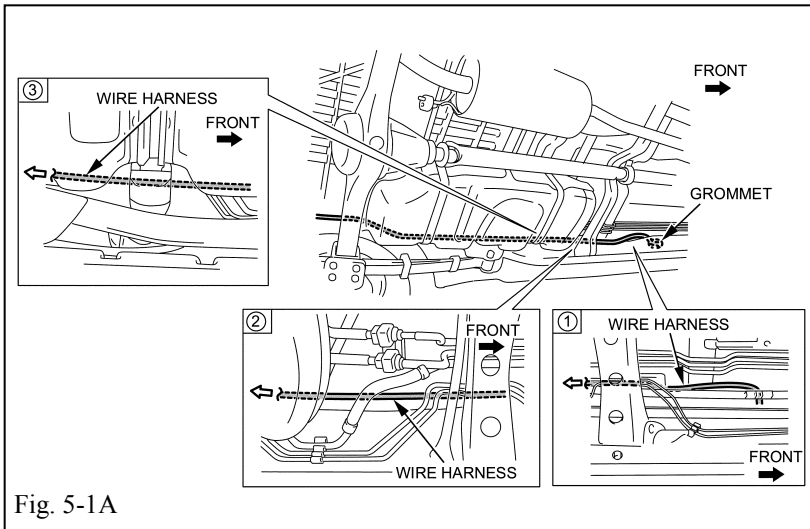

Fig. 5-1A

5. D-cab (Long) truck under bed section

(a) Routing of wire harness (underside of vehicle)

- (1) Route the 4-pin wire harness as shown in each figure. (Fig. 5-1A) (Fig. 5-1B)

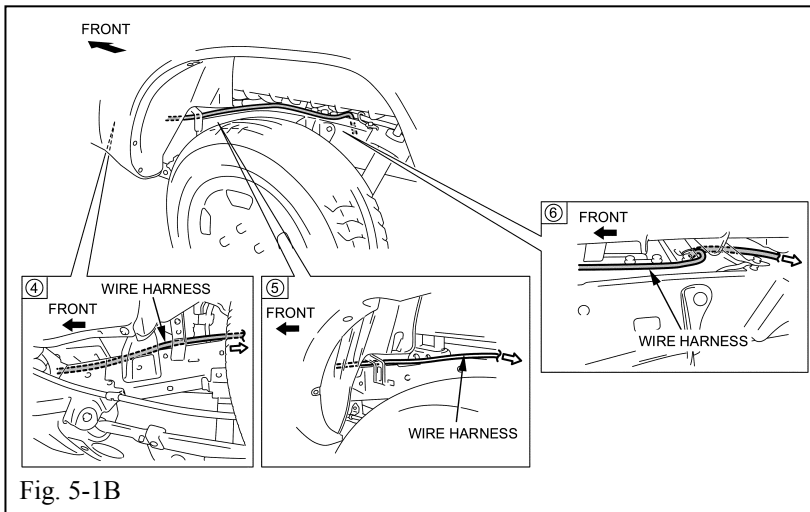

Fig. 5-1B

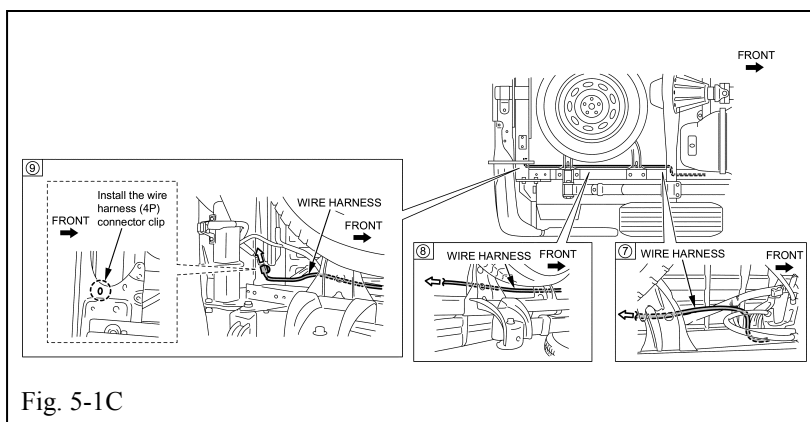
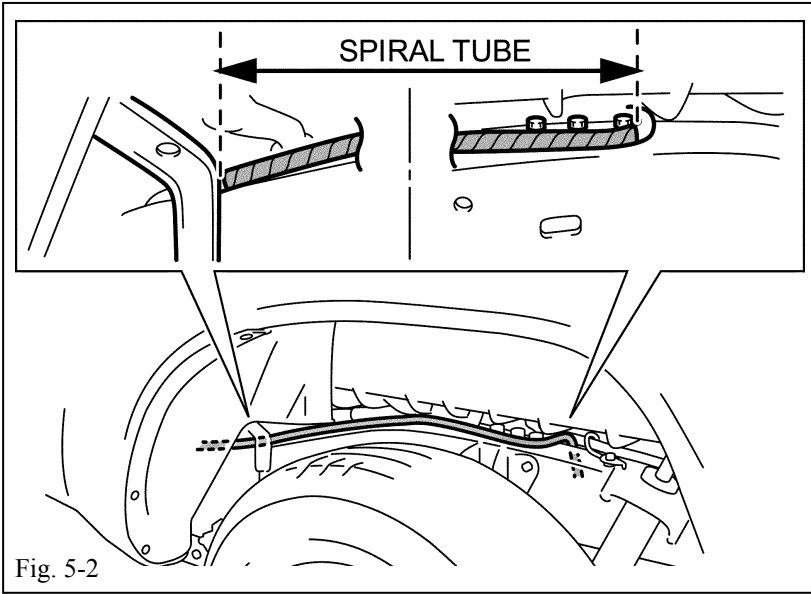

Fig. 5-1C

- (2) Install the wire harness 4-pin connector clip to the position illustrated. (Fig. 5-1C)



(b) Positioning of wire harness

- (1) Route the wire harness spiral tube to the position in the figure. (Fig. 5-2)

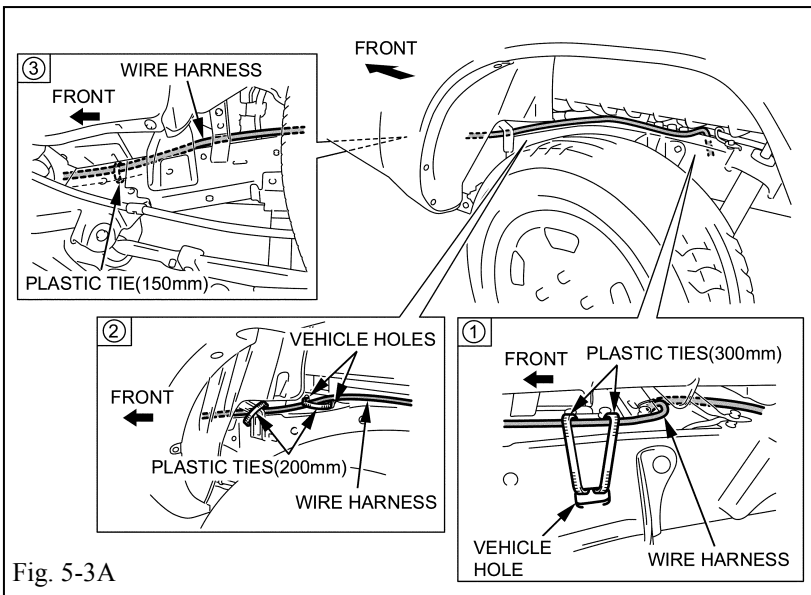

(c) Securing the wire harness (underside of vehicle)

- (1) Install the wire harness plastic ties as shown in the figure. Use the correct amount of ties as listed in the tables below. (Fig. 5-3A) (Fig. 5-3B)

PLASTIC TIES	
SIZE	QTY
150	1
200	2
300	2

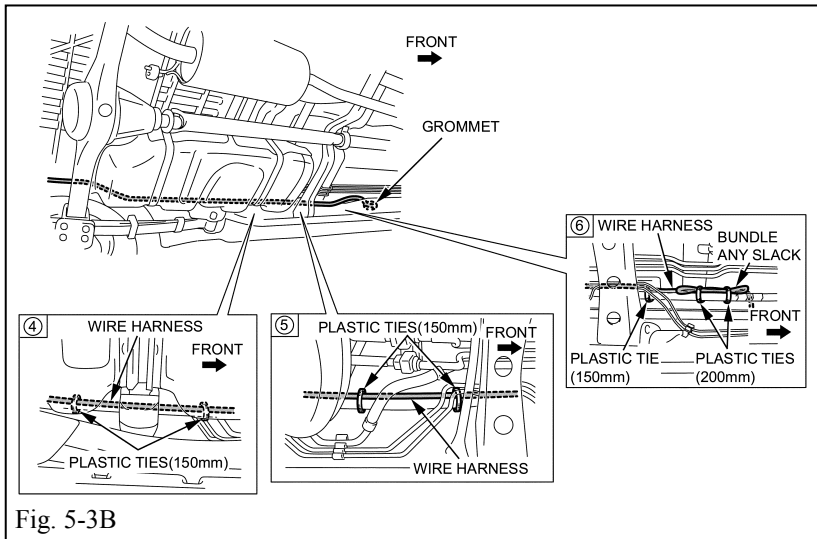

PLASTIC TIES	
SIZE	QTY
150	5
200	2
300	0

Fig. 5-3B

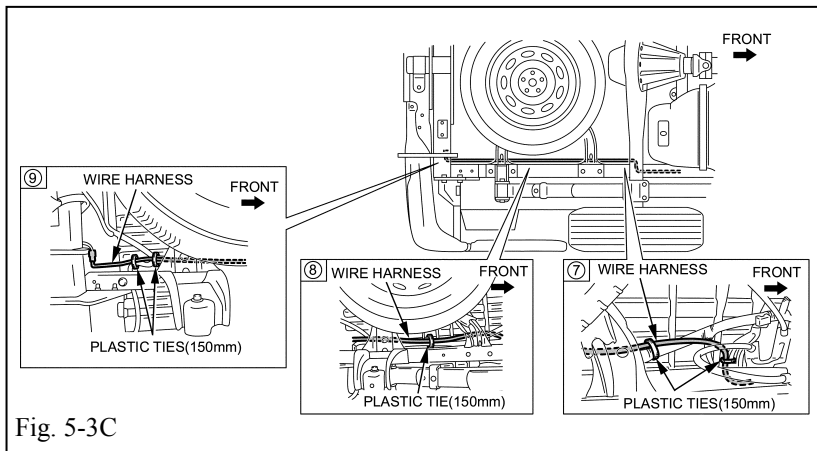

Fig. 5-3C

- ⚠** (2) Secure the wire harness so that it does not interfere with the brake line, fuel line, and others. Use the correct amount of ties as listed in the table below. (Fig. 5-3C)

PLASTIC TIES	
SIZE	QTY
150	5
200	0
300	0

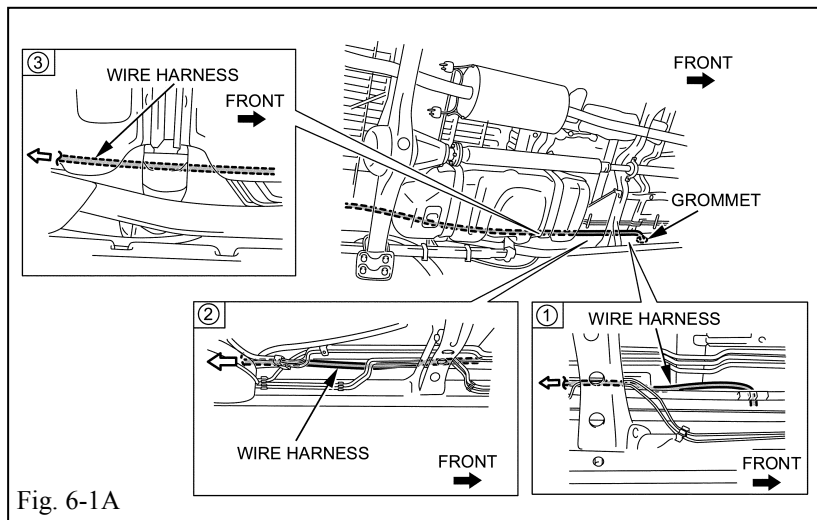

Fig. 6-1A

6. D-cab (Super Long) truck under bed section

- (a) Routing of wire harness (underside of vehicle)

- (1) Route the 4-pin wire harness as shown in each figure. (Fig. 6-1A) (Fig. 6-1B)

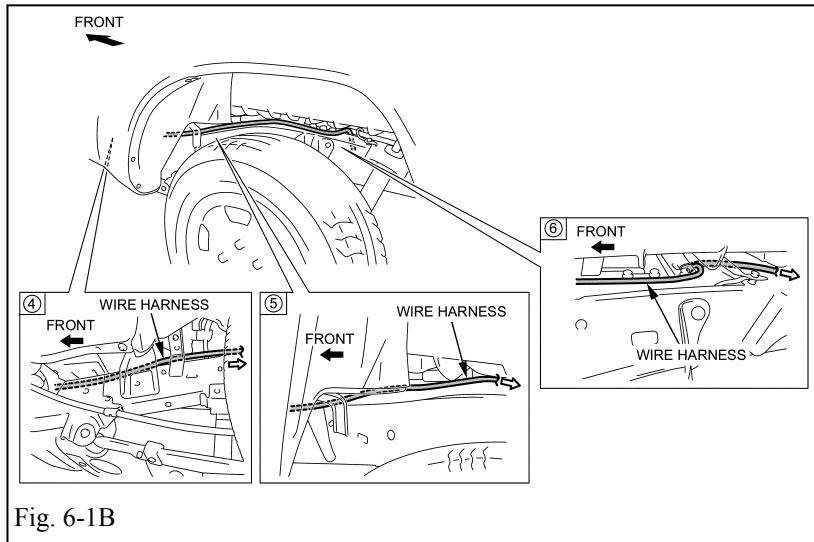

Fig. 6-1B

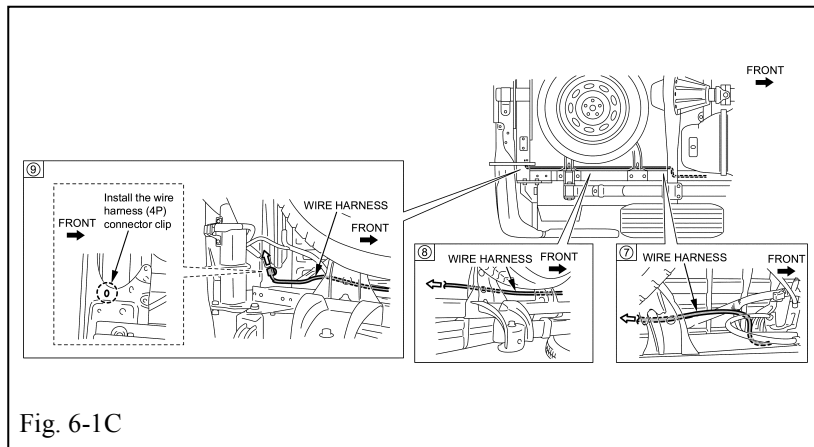

Fig. 6-1C

- ⚠ (2) Install the wire harness 4-pin connector clip to the position shown in the figure. (Fig. 6-1C)

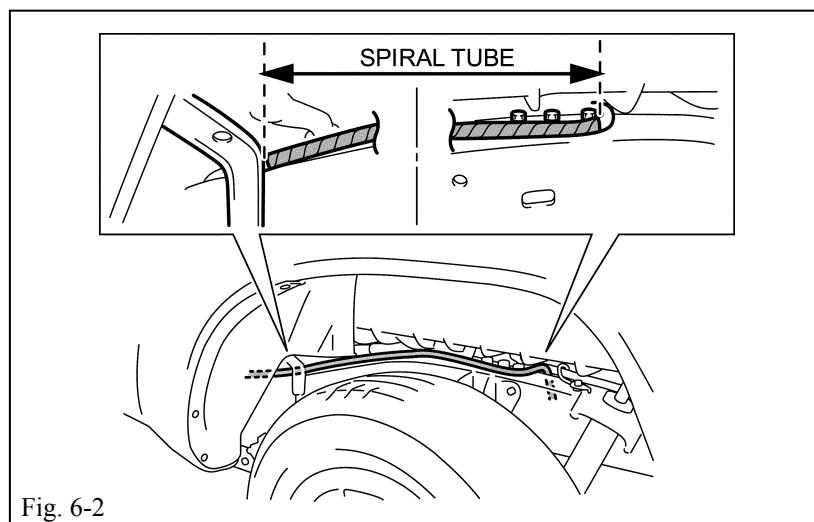

Fig. 6-2

- (b) Positioning of wire harness
 - (1) Route the wire harness spiral tube to the position shown in the figure. (Fig. 6-2)

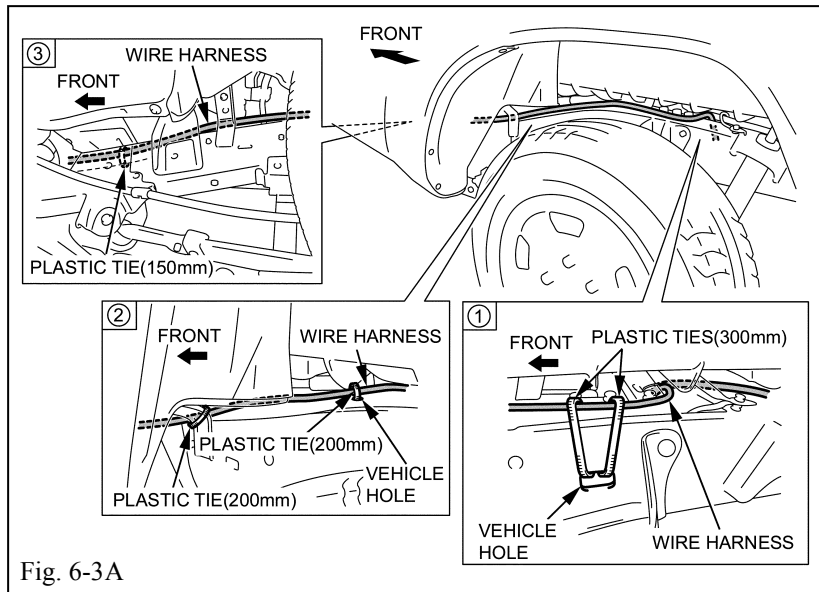

Fig. 6-3A

(c) Securing the wire harness (underside of vehicle)

- Install the wire harness plastic ties as shown in the figure. Use the correct amount of ties as listed in the tables below.

(Fig. 6-3A) (Fig. 6-3B)

PLASTIC TIES	
SIZE	QTY
150	1
200	2
300	2

PLASTIC TIES	
SIZE	QTY
150	6
200	2
300	0

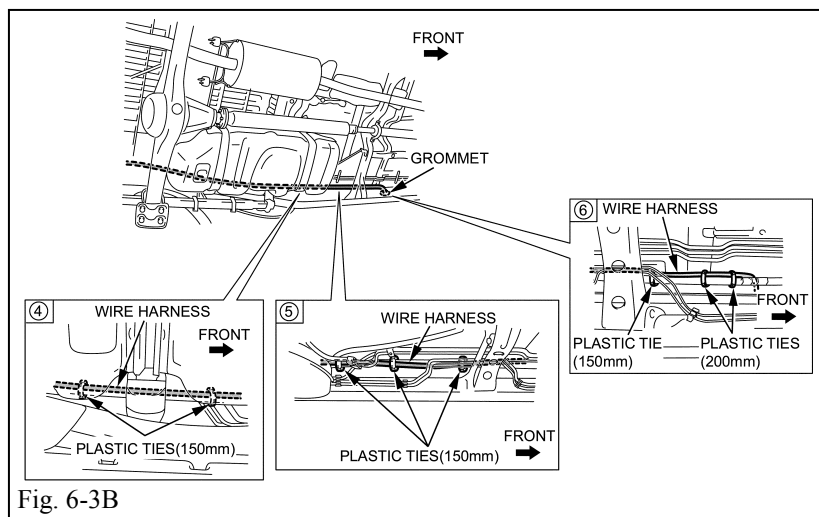

Fig. 6-3B

- Fix the wire harness so that it does not interfere with the brake line, fuel line, and others. (Fig. 6-3C)

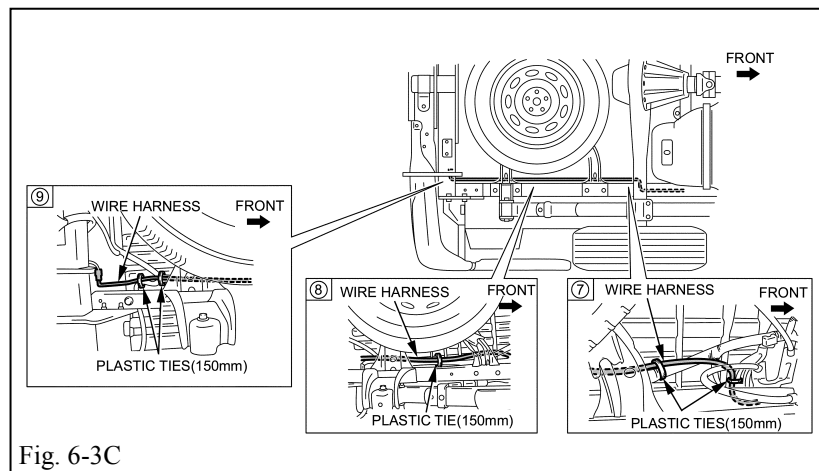

Fig. 6-3C

PLASTIC TIES	
SIZE	QTY
150	5
200	0
300	0

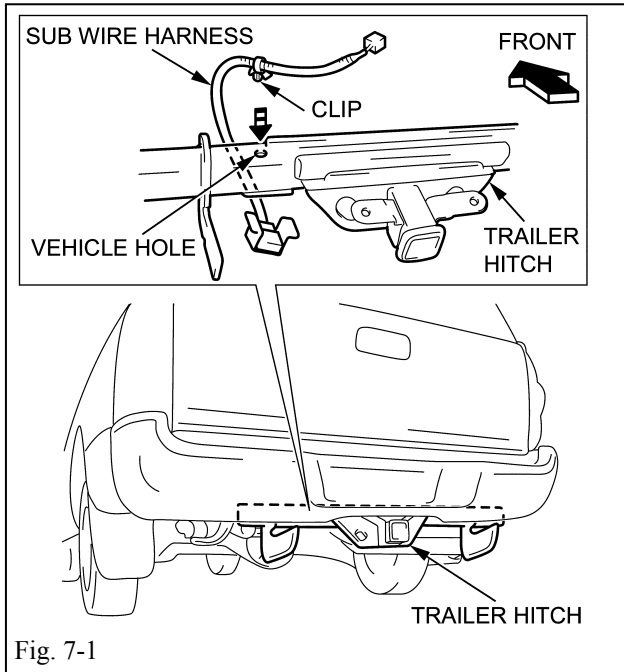

Fig. 7-1

7. Securing sub wire harness

(a) Securing sub wire harness clip

- (1) Secure the sub wire harness clip to the trailer hitch plug. (Fig. 7-1)

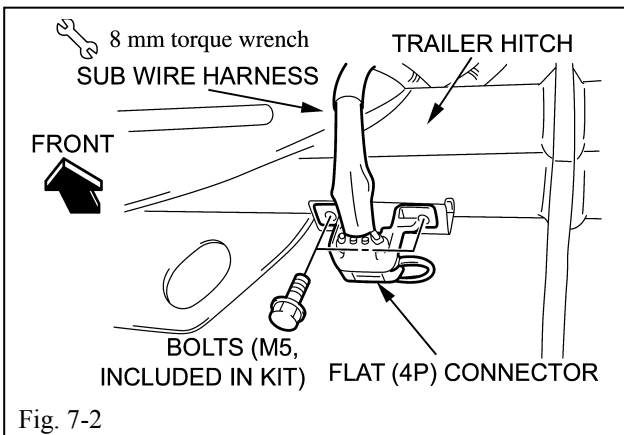

Fig. 7-2

(b) Fastening flat 4-pin connector

- (1) Fasten flat 4-pin connector with 2 bolts (M5) (included in kit). (Fig. 7-2)

- ⚠ (2) Torque bolts to: 3.9 N•m [36 lbf•in] (Fig. 7-2)

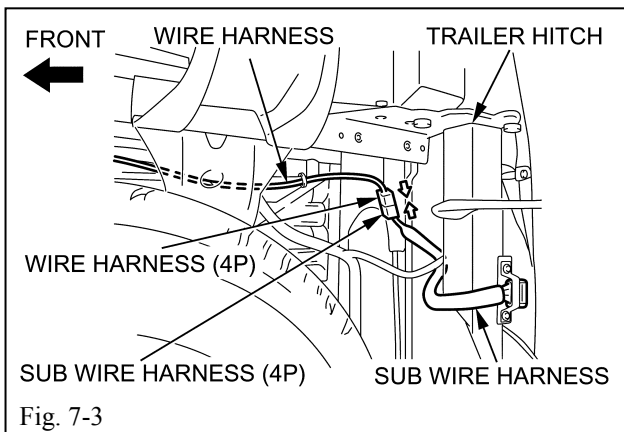
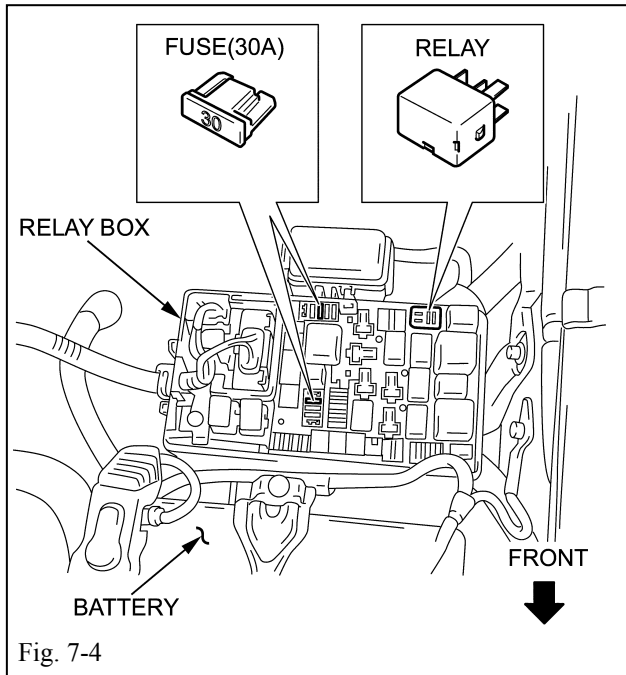

Fig. 7-3

(c) Connecting the 4-pin wire harness to the 4-pin sub wire harness

- (1) Connect the 4-pin wire harness to the 4-pin sub-wire harness connector. (Fig. 7-3)



(d) Fuse (30A) and towing tail relay installation.

- (1) If applicable, install two fuses (30A) of the kit at the position in the figure on the left. If vehicle has fuses installed, discard the kit supplied fuses. (Fig. 7-4)
- (2) Install the towing tail relay to position shown in the figure on the left. (Fig. 7-4)



(3) Pay attention to the following points when handling the towing tail relay.



(i) Avoid striking the towing tail relay.

- Never use a relay that has been dropped.
- Do not strike or use undue force when installing the towing tail relay to the vehicle.

It may damage the towing tail relay.



(ii) Do not touch the terminal directly with fingers.

Contamination of any oils or grease may impair the operation of the towing tail relay (including oil from hands).



(iii) Do not apply lubrication oil or grease to the terminal.

The terminal generates heat and it may lead to internal overheating and failure.

(e) Put Owner's Manual into the glove box.

(f) Reconnect the vehicle's negative battery cable at a 45° angle. (Fig. 7-5)



(1) Torque nut to: 5.4 N•m [48 lbf•in] (Fig. 7-5)



Torque: 5.4 N•m [48 lbf•in]



(2) Be careful not to touch the positive battery terminal. (Fig. 7-5)

(g) Reinstallation

(1) Reinstall all temporarily removed parts.

(h) Function check

(1) Perform functional verification.

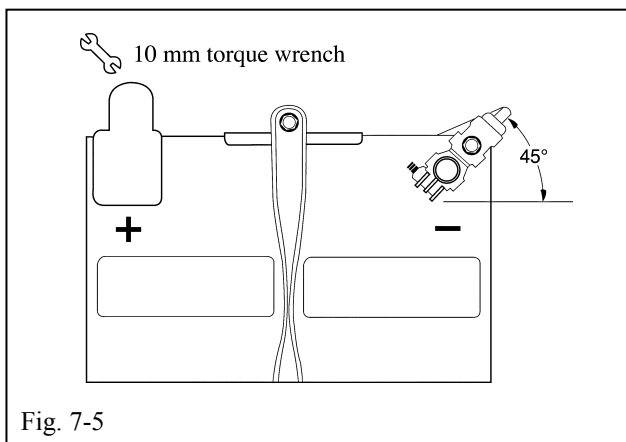

TOYOTA TACOMA 2012 - TRAILER WIRE HARNESS
Checklist - these points **MUST** be checked to ensure a quality installation.

Check:

Look for:

Vehicle Appearance Check

- Visual Inspection
(After accessory installation and removal of protective cover(s))

Ensure no damage (including scuffs and scratches) was caused during the installation process.

Panels should fit and align properly.

(For PPO installations, refer to TMS Accessory Quality Shipping Standard)

Accessory Function Checks

- Faults in the wiring harness installation.
- Converter mounting.

- Wire harness.
- Plastic tie locations.
- Removed parts.

Correct routing of the wire harness.

Pushing or pulling of the converter by any outside force.

Pinching of the wire harness.

Positioning of the plastic tie locations.

Scratches or other damage.

TOYOTA TACOMA 2012 - TRAILER WIRE HARNESS
 Checklist - these points **MUST** be checked to ensure a quality installation.

<u>Check:</u>	<u>Look for:</u>
<p><u>Vehicle Function Checks</u></p> <p>With the Special Service Tool (SST) (Part Number 00002-62195) attached to the trailer sub wire harness plug and with the ignition in ON position perform the following steps:</p> <p><input type="checkbox"/> Turn on headlamps.</p> <p><input type="checkbox"/> Turn on left turn signal.</p> <p><input type="checkbox"/> Turn on right turn signal.</p> <p><input type="checkbox"/> Apply foot brake.</p> <p><input type="checkbox"/> Turn on left turn signal and apply foot brake.</p> <p><input type="checkbox"/> Turn on right turn signal and apply foot brake.</p> <p><input type="checkbox"/> Turn on hazard lights switch.</p>	<p>Marker and tail lights on both SST and vehicle are lit.</p> <p>Left turn lights on both SST and vehicle are flashing.</p> <p>Right turn lights on both SST and vehicle are flashing.</p> <p>Stop lights on both SST and vehicle are lit.</p> <p>Left turn lights are flashing and right stop lights are lit on both SST and vehicle.</p> <p>Right turn lights are flashing and left stop lights are lit on both SST and vehicle.</p> <p>All turn signal lights are flashing on both SST and vehicle.</p>

TOYOTA TACOMA 2012 - TRAILER WIRE HARNESS

Checklist - these points **MUST** be checked to ensure a quality installation.

Check:

With hazard lights switch on, apply the foot brake.

Turn off the hazard light switch, apply the foot brake.

The following checks are to be performed with the ignition switch off.

Turn on headlamps.

Apply foot brake.

Turn on left turn signal.

Turn on right turn signal.

Turn on left turn signal and apply foot brake.

Turn on right turn signal and apply foot brake.

With hazard lights switch on, apply the foot brake.

Turn off the hazard light switch, apply foot brake.

Look for:

Both stop lights on the vehicle are lit, both turn/stop lights on the SST and the turn lights on the vehicle are flashing.

Both turn/stop lights on the SST and the stop lights on the vehicle are lit.

Marker and tail lights on both SST and vehicle are lit.

Stop lights on both SST and vehicle are lit.

Left turn lights are not lit on both SST and vehicle.

Right turn lights are not lit on both SST and vehicle.

Both stop lights are lit and not flashing on both SST and vehicle.

Both stop lights are lit and not flashing on both SST and vehicle.

All turn signal lights are flashing on both SST and vehicle.

Both stop lights on the vehicle and the turn/stop lights on the SST are lit, but not flashing.

WIRING DIAGRAM

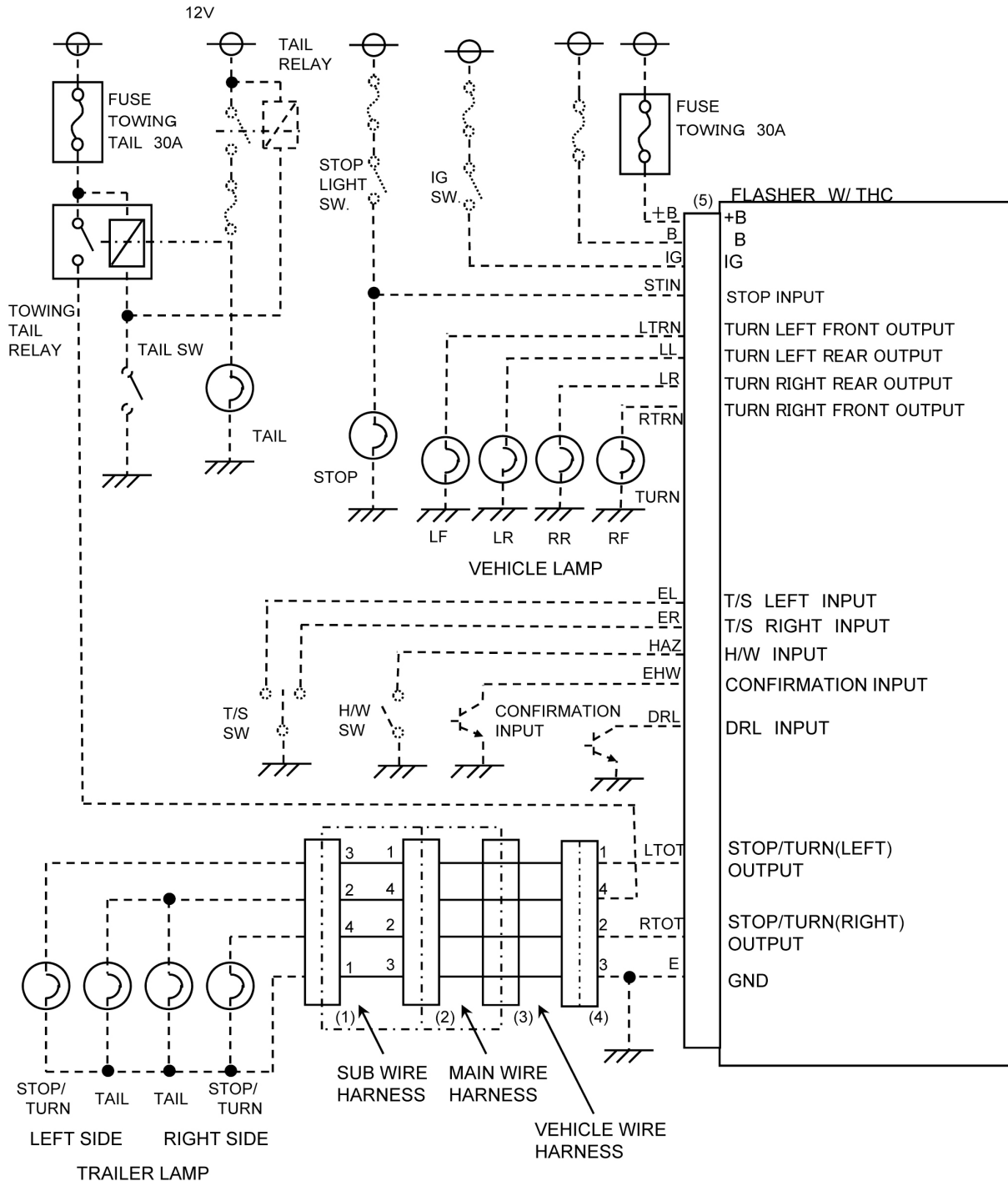

CONNECTOR (FEMALE)

